

TWIN MIRROR PASSIVE INFRARED SENSOR

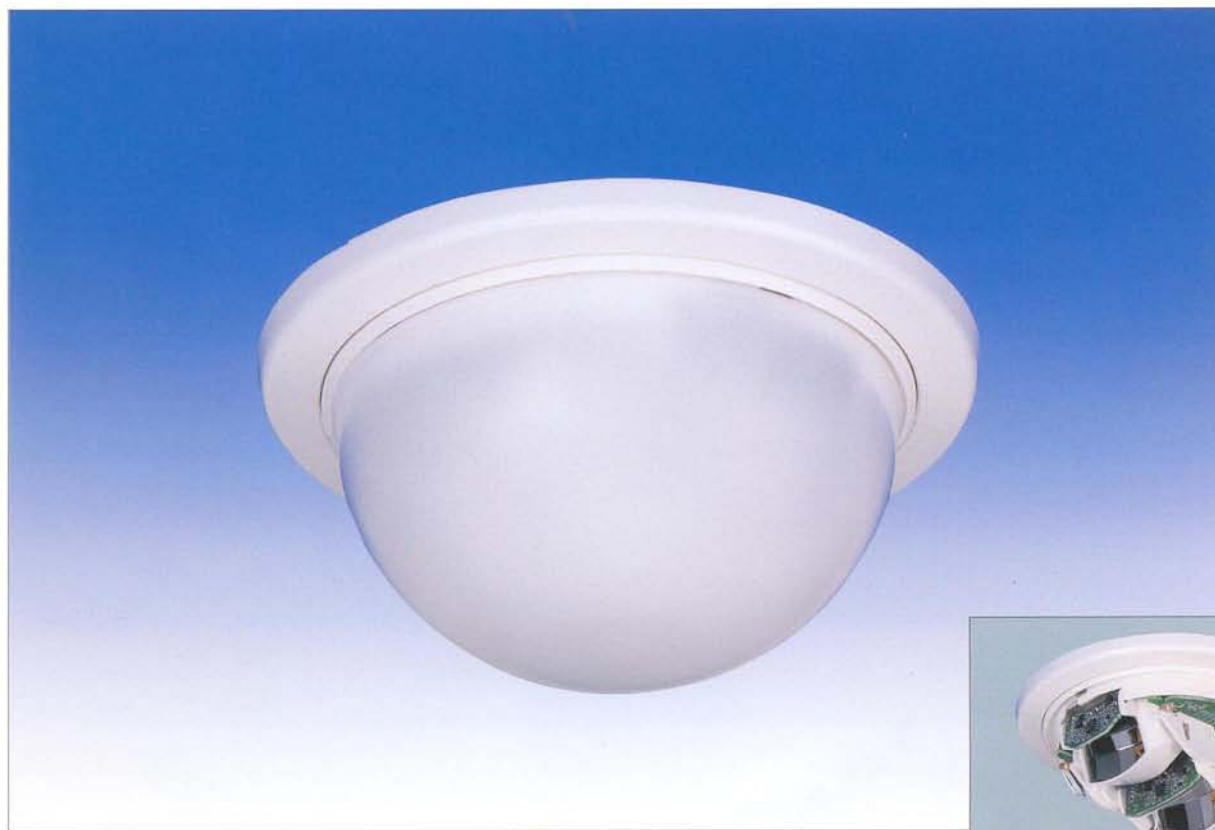

PA-6612E (WIDE ANGLE PROTECTION : 40' (12m))

JAPAN (PATENT : 1) / U.S (PATENT : 1) / U.K (PATENT : 1)
GERMANY (PATENT : 1) / FRANCE (PATENT : 1) REGISTERED



Enhanced false alarm reduction due to small animals by our patented unique twin optical system.

TWIN MIRROR OPTICAL SYSTEM

The unique combination of a pair of optical units (twin mirror and two twin pyro) yields original protection area, by which the discriminating capability between human body and small animals is increased. This results in drastical reduction of false alarms due to small animals. (The current Quad PIR usually has the weak point, that the discriminating capability varies depending on the protection distance.)

PA-6612E has overcome this weak point by the newly developed twin mirror technology, which enables non-linear control of zone disposition depending on the protection distance, in addition to the object size discriminating capability similar to the current Quad PIR.

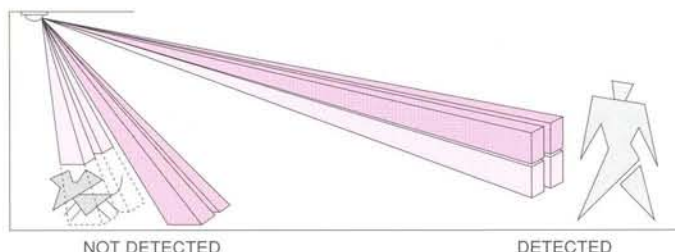

EASY INSTALLATION

The sensor unit can be snapped into and out of the base unit.
One touch operation eases installation in high places.

SILENT RELAY

Photo-mos relay adopted at alarm output. Completely noiseless by eliminating the movable part which is inside of the relay.

HIGH STABILITY

Signal processing by the original CPU.
Excellent R.F.I. and noise immunity.
Good protection against insect intrusion.

SENSITIVITY SELECTABLE

Sensitivity is adjustable : 60%, 80%, 100% and 120%

PULSE COUNT SELECTABLE

Mode selector allows setting for 1, 2, 3, or 4 triggers to initiate an alarm output to suite its application.

ALARM CONTACT SELECTABLE

Mode selector allows N/O or N/C contact to be selected.

AUTO/MANUAL MEMORY

Alarm memory can be either automatically or manually controlled.

OTHER FEATURES

Wall/Ceiling mountable with optional attachment BCW-401.

TWIN MIRROR PASSIVE INFRARED SENSOR

COVERAGE

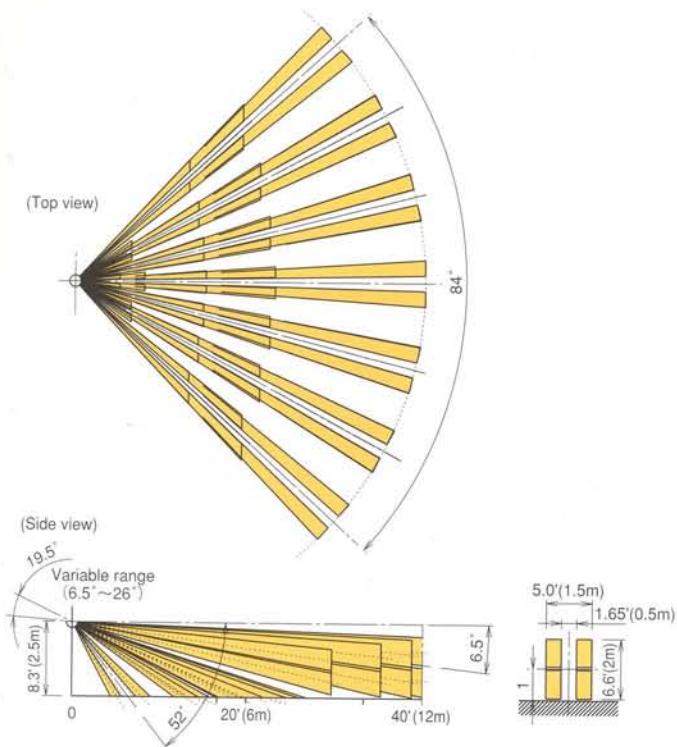

EXTERNAL DIMENSIONS

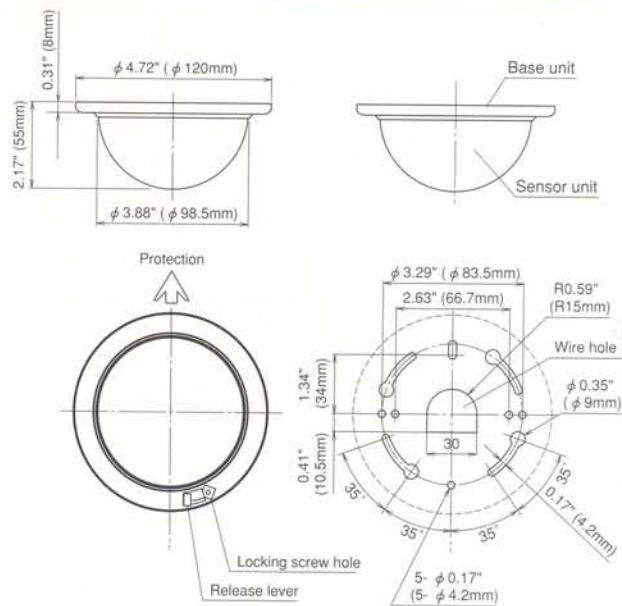

OPTIONAL

- Wall mount attachment (BCW-401)
- Wall mount attachment (BL-5000)



TERMINAL ARRANGEMENT

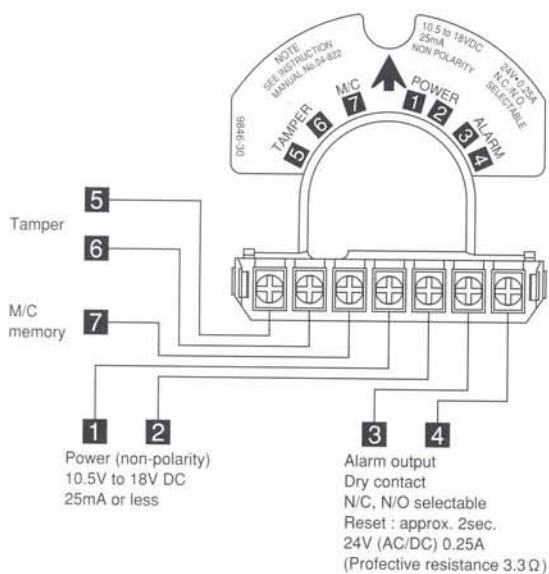

SPECIFICATIONS

Model	PA-6612E
Detection system	Passive infrared
Coverage	Wide angle 40' (12m) Max.
Sensitive zone	17pairs (64)
Supply voltage	10.5 to 18V DC (non-polarity)
Current consumption	25mA Max.
Alarm signal	Dry contact (N/C, N/O selectable) Reset: Approx. 2sec., 24V, 0.25A Max. (protective resistance 3.3Ω)
Alarm memory	Auto : 3 minutes flashing, 47 minutes lighting and automatically reset Manual : Manual control
Alarm LED	Red : Flashing at warning up Lighting at alarm (LED disabled)
Memory LED	Yellow : Flashing at memory activated Lighting at memory indication
Adjustment	Vertically 19.5°, Horizontally 25° (on mounting hole of base)
Count changeover	1/2/3/4 changeover
Ambient temperature range	+5° F to +131° F (-15°C to +55°C) without condensation
Mounting position	Indoor ceiling (wall mount with optional attachment BCW-401)
Wiring connection	Terminals on separate base unit
Weight	4.7oz (135g)
Appearance	Body : ABS resin Cover : PE resin
Accessory	Tapping screw: 2 pcs. Sensor locking screw: 1 pce.

The specifications are subject to change without notice.

Please note : This sensor is designed to detect intrusion and to initiate an alarm; it is not a burglary-preventing device. TAKEX is not responsible for damage, injury or losses caused by accident, theft, Acts of God (including inductive surge by lightning), abuse, misuse, abnormal usage, faulty installation or improper maintenance.

LEAF02-04P14-5

TAKEX

In Japan

Takenaka Engineering Co., Ltd.
83-1, Gojo-sotokan,
Higashino, Yamashina-ku,
Kyoto 607-8156, Japan
Tel : 81-75-501-6651
Fax: 81-75-593-3816
<http://www.takex-eng.co.jp/>

In the U.S.

Takex America Inc.
230 E. Caribbean Drive
Sunnyvale,
CA 94089, U.S.A.
Tel : 408-747-0100
Fax: 408-734-1100
<http://www.takex.com>

In Australia

Takex America Inc.
Unit 16, 35 Garden Road,
Clayton, Victoria 3168,
Australia
Tel : 03-9546-0533
Fax: 03-9547-9450

Takex America Inc.

Brisbane office : 1/50 Logan
Road, Woolloongabba
Queensland
4102, Australia
Tel : 07-3891-3344
Fax: 07-3891-3355

In the U.K.

Takex Europe Ltd.
Pulnix House, Aviary Court,
Wade Road, Basingstoke,
Hampshire. RG24 8PE, U.K.
Tel : 01256-475555
Fax: 01256-466268
<http://www.takexeuropa.com>