

PHOTOELECTRIC BEAM SENSOR

(INTELLIGENT TWIN SERIES)



- PB-20TE** : Outdoor 66ft.(20m)/Indoor 135ft.(40m)
- PB-40TE** : Outdoor 135ft.(40m)/Indoor 270ft.(80m)
- PB-60TE** : Outdoor 200ft.(60m)/Indoor 400ft.(120m)



The TAKEX intelligent "TWIN" photoelectric beam is designed to meet the highest standards of quality and reliability for photoelectric beam intrusion detection. Unique twin beams are synchronized to work together to reinforce the range and stability in severe weather conditions. The "intelligence" comes from having 4 different selectable frequencies which allow the stacking of beam sets to create a "Wall of Light". The system has a rotary optical system for easy installation and the special lens design aids in proper alignment.

SELECTABLE FREQUENCY

Includes 4 separate selectable frequencies which can stack up without crosstalk for high security applications.

HIGH RELIABILITY

Synchronized twin beams reduce false alarms caused by flying birds and falling leaves. The outdoor maximum arrival distance is 10 times longer than the operating distance, which allows for reliable operation in poor weather

EXTERNAL LIGHT PROTECTION

Trouble-free condition in 50,000 lux illumination fluctuation is assured by external light compensation circuit a filter, specially designed, that cuts visible rays effectively. Excellent tolerance against sun light, automobile head light, fluorescent light or mercury light.

EASY BEAM ALIGNMENT

The special view finder allows for fast aiming and assures good alignment. Equipped with monitor jack to check sensitivity.

ROTARY OPTICAL SYSTEM

The optical system of both the transmitter and receiver can be rotated a full 180° which allows for side aiming.

Therefore the units do not have to be mounted face to face and the beam direction can not be discerned by simple observation.

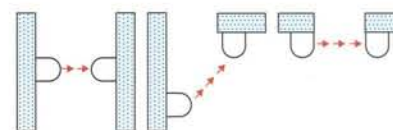

Utility model registered : 3
Trade mark registered : 1
Design pending : 1

PROTECTION AGAINST FROST/DEW

As a special hood is attached on sensor cover, beam protection continues without interruption even when the cover is screened by frost or dew.

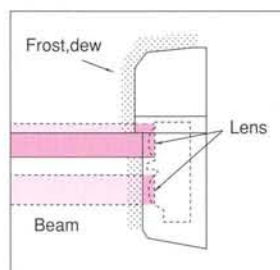

INSECT PROTECTION

A sealed optical system prevents intrusion and interference by insects.

OTHER FEATURES

- * Automatic Gain Control circuit loaded
- * Wide adjustment (horizontally $\pm 90^\circ$, vertically $\pm 10^\circ$)
- * Pole mounting kit included



Pole mount

PHOTOELECTRIC BEAM SENSOR

COVERAGE

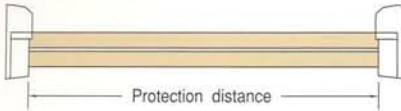

| | |
|-----------------|-------------|
| PB-20TE Outdoor | 66' (20m) |
| Indoor | 135' (40m) |
| PB-40TE Outdoor | 135' (40m) |
| Indoor | 270' (80m) |
| PB-60TE Outdoor | 200' (60m) |
| Indoor | 200' (120m) |

OPTIONAL

● Pole

- KP-100 (100cm, 2pcs./set)
- KP-150 (150cm, 2pcs./set)



- Pole cover (2pcs./set)
BP-60TE
(pole cap, screw included)



- Housing case
KH-120



TERMINAL ARRANGEMENT

[Transmitter]



Power
12VDC to 30VDC (non-polarity)

[Receiver]



Power
12V-30VDC
(non-polarity)
Alarm
COM
Alarm output
Dry contact relay
output 1c,30V
(AC/DC),0.5A
NC
NO
Tammer
output
Dry contact
relay output
1b,30V
(AC/DC),0.5A

EXTERNAL DIMENSIONS

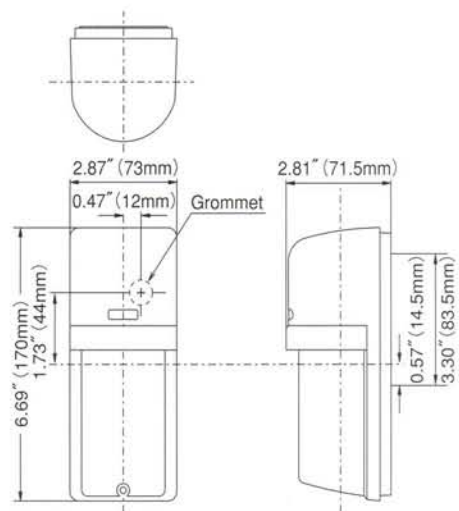

SPECIFICATIONS

The specifications are subject to change without notice.

| Model | PB-20TE | PB-40TE | PB-60TE |
|---------------------------|---|---|--|
| Detection system | Simultaneous breaking of 2 beams | | |
| Infrared beam | LED pulsed beam Double modulation | | |
| Protection distance | Outdoor 66' (20m) or less Indoor 135' (40m) or less | Outdoor 135' (40m) or less Indoor 270' (80m) or less | Outdoor 200' (60m) or less Indoor 400' (120m) or less |
| Max. beam range | Outdoor 660' (200m) Indoor 660' (200m) | Outdoor 1350' (400m) Indoor 1350' (400m) | Outdoor 2000' (600m) Indoor 2000' (600m) |
| Response time | 50msec. to 700msec. (Variable at pot) | | |
| Supply voltage | 12V to 30VDC (Non-polarity) | | |
| Current consumption | 55mA or less | 75mA or less | 80mA or less |
| Alarm output | Dry contact relay output form C Contact action : Interruption time + delay time (1 to 3sec.) Contact capacity : 30V (AC/DC) 0.5A or less | | |
| Tammer output | Dry contact relay 1b (N/C) Action : Activated when cover is detached Contact capacity : 30V (AC/DC) 0.5A or less | | |
| Alarm LED | Red LED (Receiver) ON : when an alarm is initiated. | | |
| Attenuation LED | Red LED (Receiver) ON : when beam is attenuated. | | |
| Functions | Beam frequency changeover (4ch.), Monitor jack output, AGC circuit, Frost proof cover | | |
| Ambient temperature range | -13°F to +140°F (-25°C to +60°C) | | |
| Mounting positions | Indoor/Outdoor | | |
| Wiring | Terminals | | |
| Weight | Transmitter : 13.3oz(380g) Receiver : 14.0oz(400g) | | |
| Appearance | PC resin(wine red) | | |

Please note : This sensor is designed to detect intrusion and to initiate an alarm; it is not a burglary-preventing device. TAKEX is not responsible for damage, injury or losses caused by accident, theft, Acts of God (including inductive surge by lightning), abuse, misuse, abnormal usage, faulty installation or improper maintenance.

LEAF 03-04R4-3

TAKE X

In Japan

Takenaka Engineering Co., Ltd.
83-1, Gojo-sotokan,
Higashino, Yamashina-ku,
Kyoto 607-8156, Japan
Tel : 81-75-501-6651
Fax : 81-75-593-3816
<http://www.takex-eng.co.jp/>

In the U.S.

TakeX America Inc.
230E, Caribbean Drive
Sunnyvale,
CA 94086, U.S.A.
Tel : 408-747-0100
Fax : 408-734-1100
<http://www.takex.com>

In Australia

TakeX America Inc.
Unit 16/35 Garden Road,
Clayton 3168 Victoria,
Australia
Tel : 03-9546-0533
Fax : 03-9547-9450

TakeX America Inc.
Brisbane office : 1/50 Logan
Road, Woolloongabba
Queensland
4102, Australia
Tel : 07-3891-3344
Fax : 07-3891-3355

In the U.K.

TakeX Europe Ltd.
TakeX House, Aviary Court,
Wade Road, Basingstoke,
Hampshire, RG24 8PE, U.K.
Tel : (+44)01256-475555
Fax : (+44)01256-466268
<http://www.takexeurope.com>